

Physics, Astrophysics and Applied Physics PhD School:
1st Year-Student Mini-Workshop

***Quantum correlations and decoherence
in systems of interest for the
quantum information processing***

Claudia Benedetti

Supervisor: Prof. M. G. A. Paris (Università degli studi di Milano)

CoSupervisor: Prof. P. Bordone (Università degli studi di Modena e Reggio Emilia)

Outline

- Introduction on quantum states
- Quantum Correlations
 - Entanglement
 - Quantum Discord
- Why?
- Decoherence
- Noise Model
- Results
- Future Perspectives

Bipartite systems: separable states

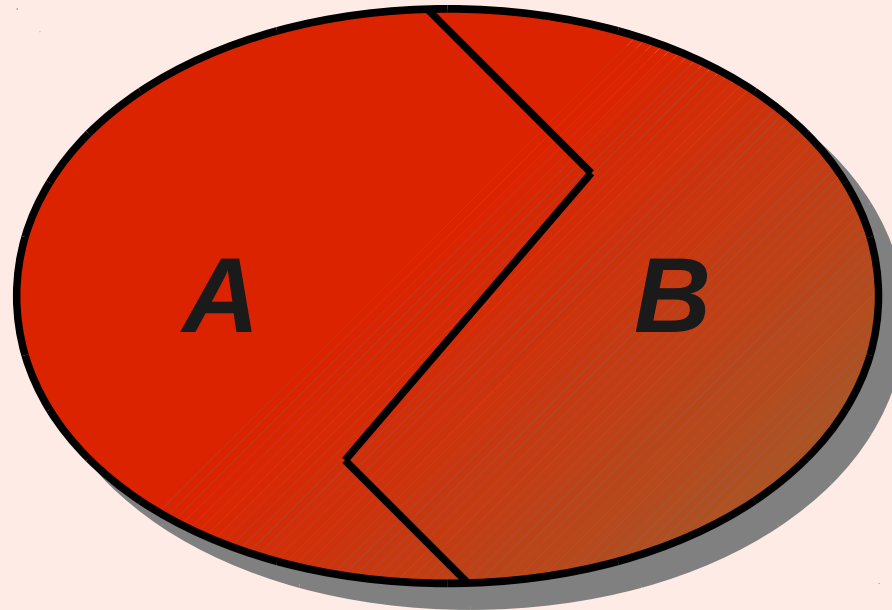

Separable pure states $|\phi\rangle = |\varphi\rangle_A \otimes |\psi\rangle_B$

Separable mixed states $\rho = \sum p_{ki} \rho_k^A \otimes \sigma_i^B$

States which cannot be written in these forms are called **entangled** states.

Quantum correlations: entanglement 1

Entanglement-separability dichotomy

$$|\Psi\rangle = \frac{1}{\sqrt{2}} \left(|\downarrow_A \uparrow_B\rangle + |\uparrow_A \downarrow_B\rangle \right)$$

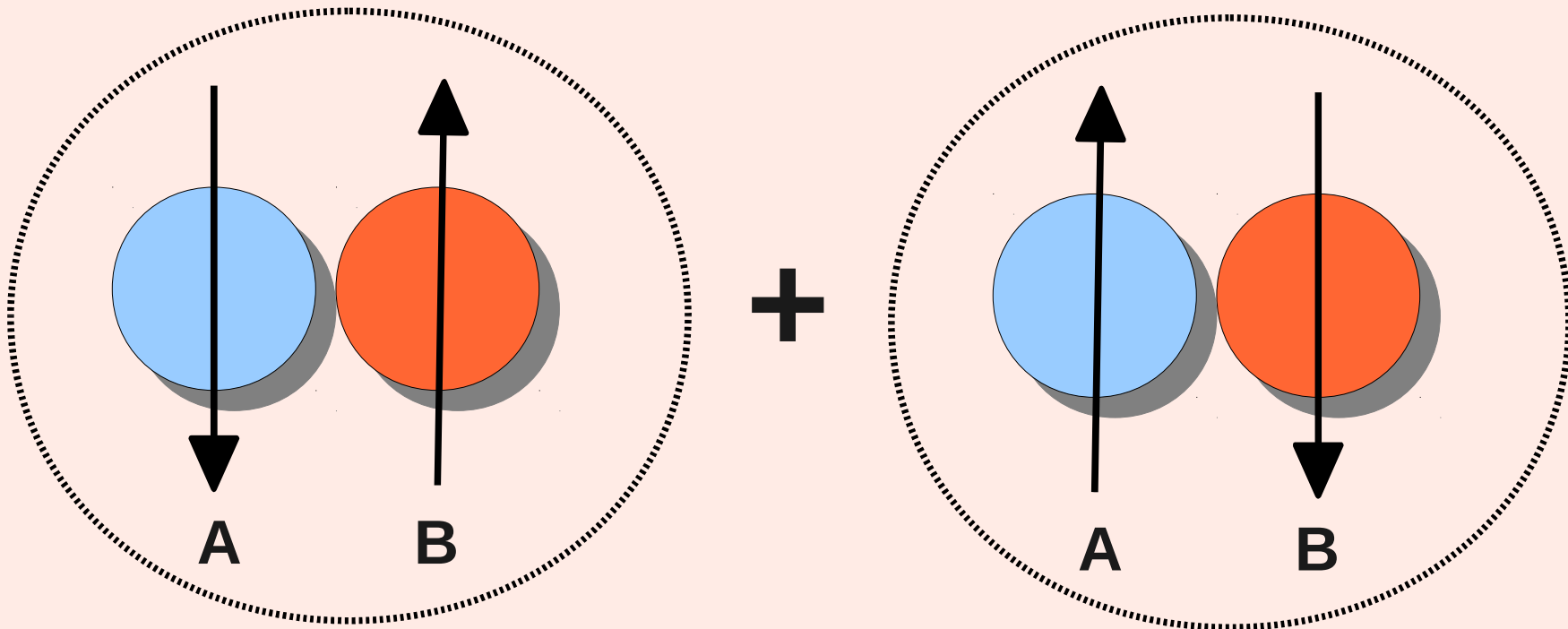

Entanglement arises from the superposition

Quantum correlations: entanglement 2

Entanglement vs separability

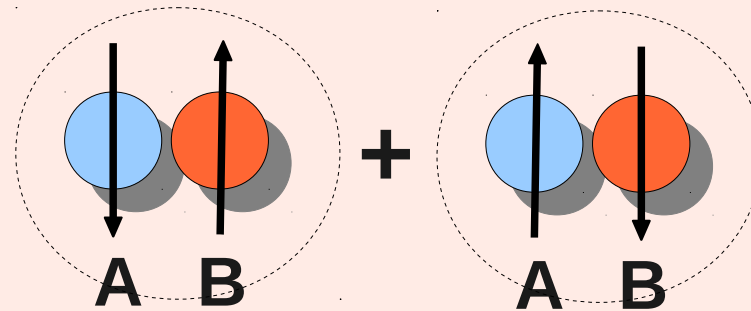

PPT criterion for entanglement: a state is entangled if its partial transpose has negative eigenvalues

Negativity:

$$N(\rho) = \sum_i \lambda_i^-[\rho^{PT}]$$

$\lambda_i^-[\rho^{PT}]$: negative eigenvalues of ρ^{PT}

$$\langle j_A k_B | \rho^{PT} | i_A l_B \rangle = \langle j_A l_B | \rho^{PT} | i_A k_B \rangle$$

Necessary and sufficient condition
for 2x2 systems

Quantum correlations: quantum discord

Entanglement has often been identified with quantum correlations,
but this is true only for pure states

—▶ There exist separable states with quantum characteristics

Quantum correlations: quantum discord 1

Entanglement has often been identified with quantum correlations,
but this is true only for pure states

—▶ There exist separable states with quantum characteristics

Ollivier and Zurek
Phys. Rev. Lett. 88, 017901 (2001)

Henderson and Vedral
J. Phys. A 34, 6899 (2001)

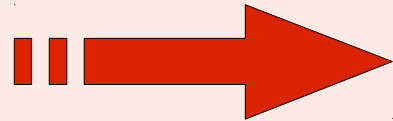

Quantum discord

$$\rho = \sum p_{ki} \rho_k^A \otimes \sigma_i^B \longrightarrow \text{LOCC}$$

Quantum correlations: quantum discord 1

Entanglement has often been identified with quantum correlations,
but this is true only for pure states

→ There exist separable states with quantum characteristics

Ollivier and Zurek
Phys. Rev. Lett. 88, 017901 (2001)

Henderson and Vedral
J. Phys. A 34, 6899 (2001)

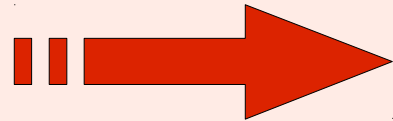

Quantum discord

$$\rho = \sum p_k \rho_k^A \otimes |\beta_k\rangle\langle\beta_k|$$

Quantum correlations: quantum discord 1

Entanglement has often been identified with quantum correlations,
but this is true only for pure states

→ There exist separable states with quantum characteristics

Ollivier and Zurek
Phys. Rev. Lett. 88, 017901 (2001)

Henderson and Vedral
J. Phys. A 34, 6899 (2001)

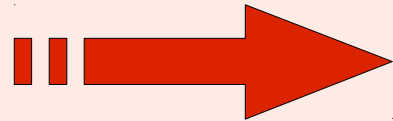

Quantum discord

$$\rho = \sum p_k \rho_k^A \otimes |\beta_k\rangle\langle\beta_k|$$

$$\rho = \sum p_k \rho_k^A \otimes \sigma_k^B$$

Quantum correlations are more general than entanglement!

Quantum correlations: quantum discord 2

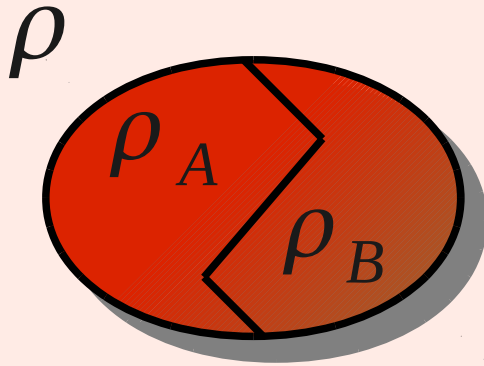

Mutual information

$$I(\rho) = S(\rho^A) + S(\rho^B) - S(\rho)$$

Measure of the total correlations of a system

von Neumann entropy: $S(\rho) := -\text{Tr}[\rho \log_2 \rho]$

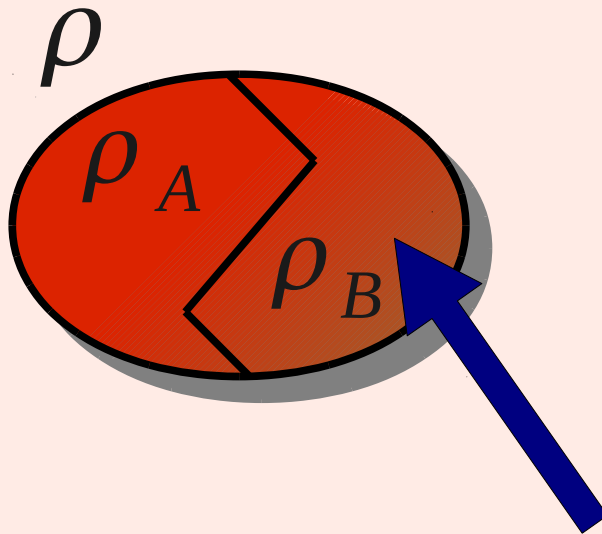

Classical correlations

$$C(\rho) = S(\rho^A) - \min_{\{\Pi_k^B\}} \sum_k p_k S(\rho_k^A)$$

Measure of the total classical correlations of a system

$\{\Pi_k^B\}$ Set of projective measurements on B

Minimizing over all possible measurements on B corresponds to finding the measurement that **disturb least** the quantum state and allows to extract the most information about A

Quantum correlations: quantum discord 3

Measure of the total quantum correlations of a system

$$\underbrace{D(\rho)}_{\text{Quantum discord}} = \underbrace{I(\rho)}_{\text{Total correlations}} - \underbrace{C(\rho)}_{\text{Total classical correlations}}$$

- Separable mixed states can have nonzero quantum discord
- Absence of entanglement does not imply classicality
- Non-classical correlations more general and more fundamental than entanglement

Why?

Entangled states

- **Quantum cryptography** Gisin. Et al. Rev. Mod. Phys. 74, 145 (2002)
- **Dense coding** Bennett and Wiesner, Phys. Rev. Lett. 69, 2881 (1992)
- **Teleportation** Bennett et al. Phys. Rev. Lett. 70, 1895 (1993)
- **Exponential speed-up of some computational tasks** Shor, J. Comp. 26, 1484 (1997)
- ...

Separable states

- **Quantum search without entanglement** Meyer Phys. Rev. Lett. 85, 2014–2017 (2000)
- **Quantum non-locality without entanglement** Bennett et al. Phys. Rev. A 59, 1070–1091 (1999)
- **Quantum computing without entanglement** Biham et al. Theor. Comput. Sci. 320 (2004) 15
- **Quantum discord as optimal resource for quantum communication** arXiv:1203.1629 [quant-ph]
- ...

Why?

- Nowadays quantum discord is a hot topic for the quantum information community.
- Resource for the quantum information processing
- ◆ Polarization qubit in quantum optics
Collaboration with I.N.Ri.M (Torino), A. Shurupov and M. Genovese
- ◆ Solid-state qubits in a noisy environment (static noise, random telegraph noise, colored noise...)
Collaboration with P. Bordone and F. Buscemi

Decoherence

Interaction with an external environment...

...destroys quantum correlations

...degrades quantum coherence

...is the main threat to the correct working of quantum processing devices (such as quantum computers)

The decay of coherence in quantum bits is the most important obstacle for constructing a working quantum computer

Every system interacts with its environment!

It is thus very important to understand how different environments can affect the dynamical evolution of quantum correlations

Decoherence

Every system interacts with its environment!

$$\frac{1}{f^\alpha}$$

- Ubiquitous noise in solid state devices
- It affects solid state **qubits**, such as charge and spin qubits
- Important at **low** frequencies
- Non-Markovian noise
- Collection of bistable fluctuators, modeling **impurities** or **defects** in the material

$\alpha = 1$ \longrightarrow Pink noise

$\alpha = 2$ \longrightarrow Brown noise

The Physical Model – Independent environments

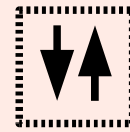
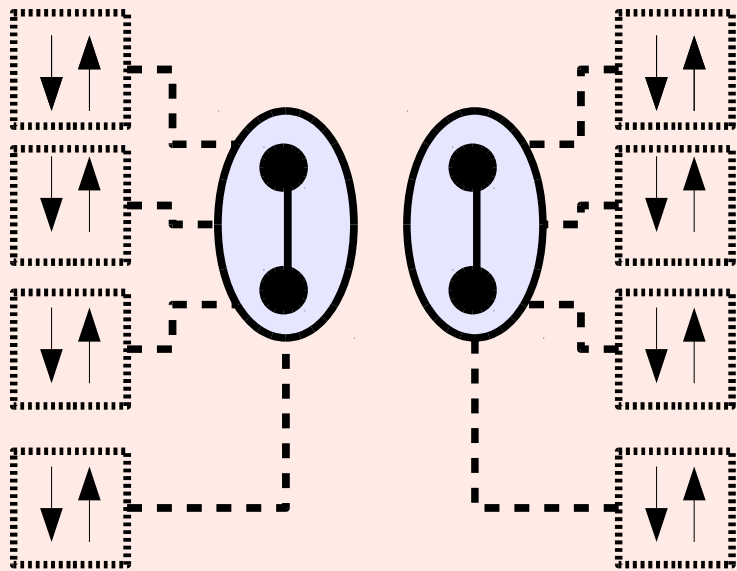

Bistable fluctuator:
It can flip between two opposite values
 $c(t) = \pm 1$ with switching rate γ

2 non-interacting qubits
Each qubit interact with a collection of bistable fluctuators

$$H = H_A \otimes I_B + I_A \otimes H_B$$

$$H_{A(B)} = \epsilon I_{A(B)} + v \sigma_x^{A(B)} \sum_{i=1}^M c_i^{A(B)}(t)$$

Every fluctuator has a switching rate γ_i taken from a distribution

$1/\gamma$ to obtain $1/f$ pink noise

$1/\gamma^2$ to obtain $1/f^2$ brown noise

The Physical Model – Common environment

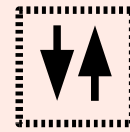
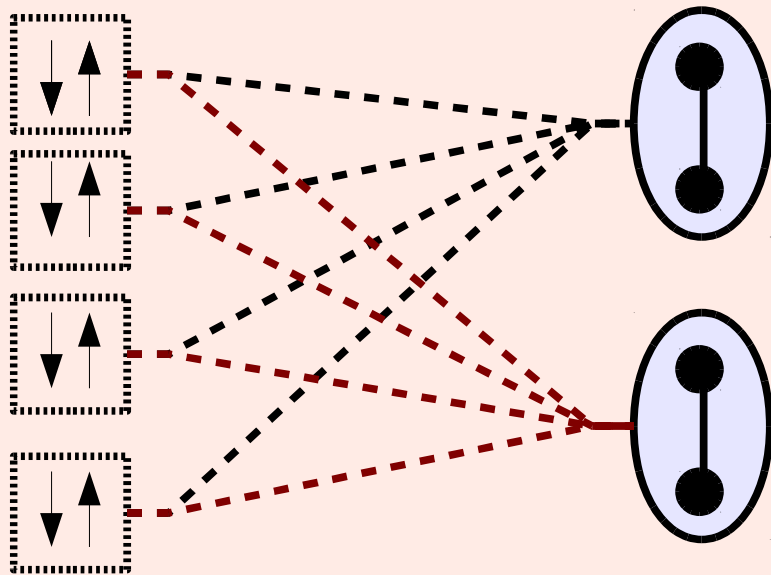

Bistable fluctuator:
It can flip between two opposite values
 $c(t) = \pm 1$ with switching rate γ

2 non-interacting qubits
Each qubit interact with a collection of bistable fluctuators

$$H = H_A \otimes I_B + I_A \otimes H_B$$

$$H_{A(B)} = \epsilon I_{A(B)} + v \sigma_x^{A(B)} \sum_{i=1}^M c_i^{A(B)}(t)$$

Every fluctuator has a switching rate γ_i taken from a distribution

$1/\gamma$ to obtain $1/f$ pink noise

$1/\gamma^2$ to obtain $1/f^2$ brown noise

The Physical Model

The total density matrix is calculated as an average over a large number of density matrices each associated to a specific sequences of parameters $c_i(t)$

$$\rho(t) = e^{-i \int H(t') dt'} \rho(0) e^{i \int H(t') dt'}$$

$$\bar{\rho}(t) = \langle \rho(t) \rangle_{\{c_i(t)\}}$$

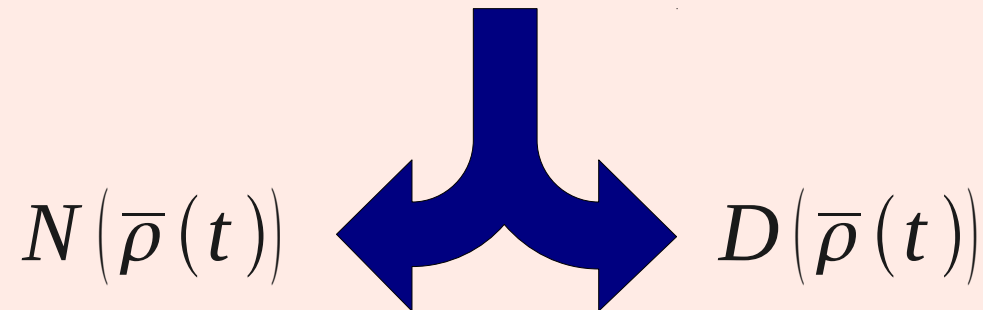

The dynamics is solved **numerically**

Monte Carlo method is used to select the switching rates of the bistable fluctuators from the γ -distributions and to determine times between following flips at a fixed rate

Results 1: 1/f noise

Different environments

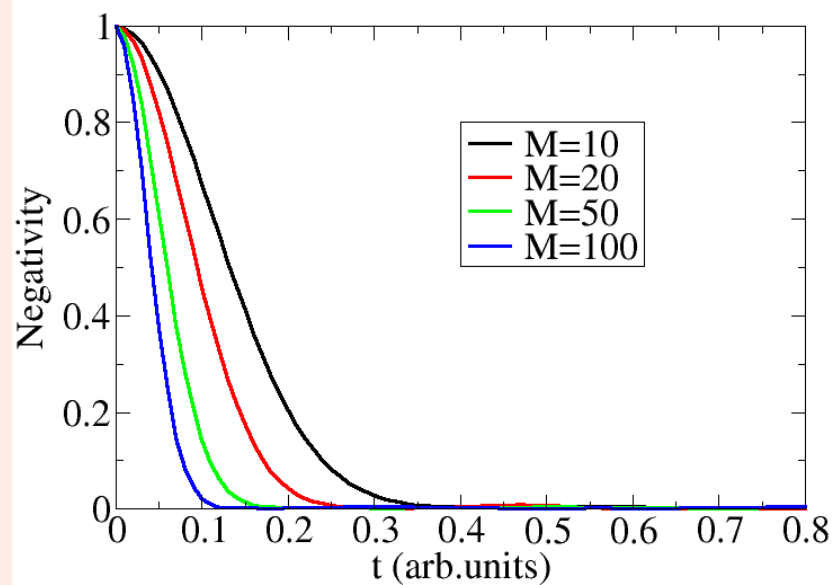

Common environment

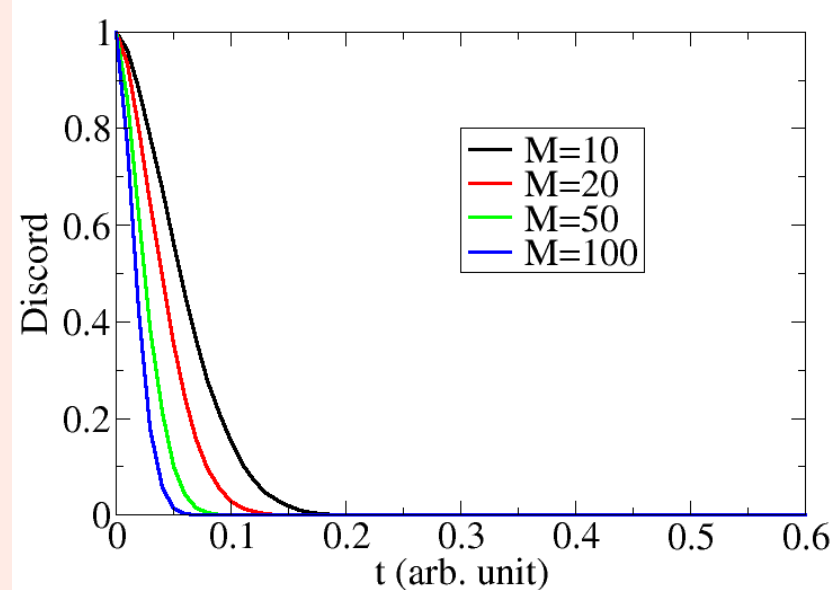
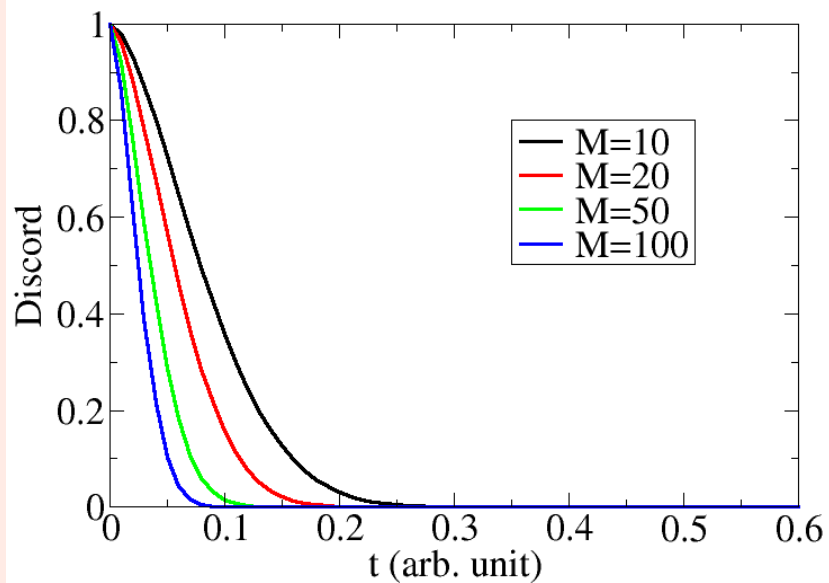
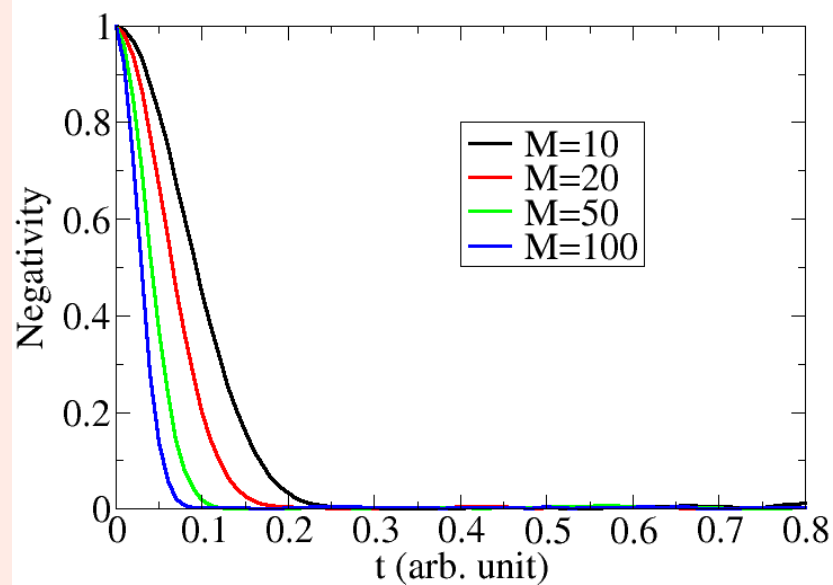

Results 2: $1/f^2$ noise

Different environments

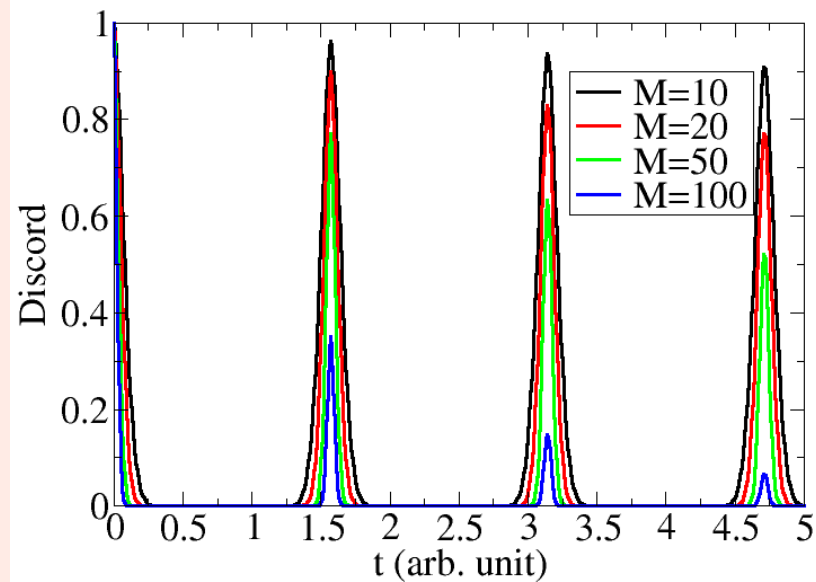
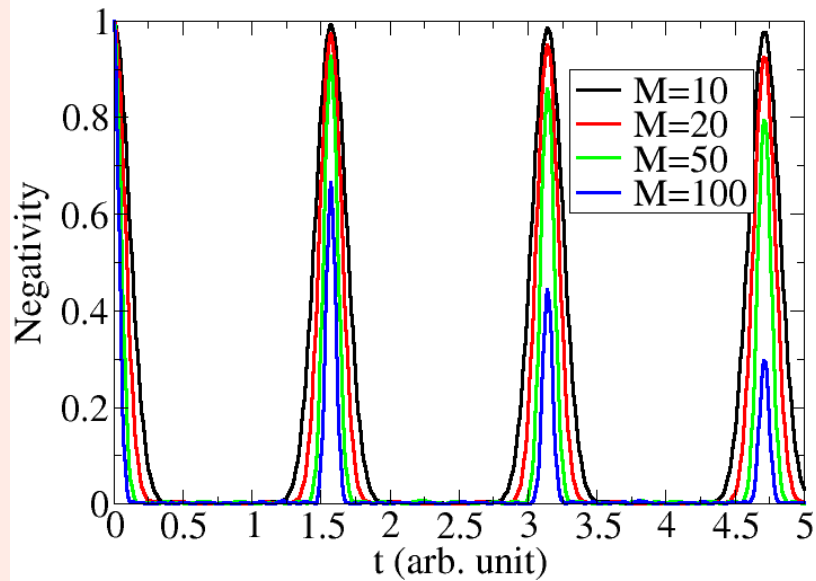

Common environment

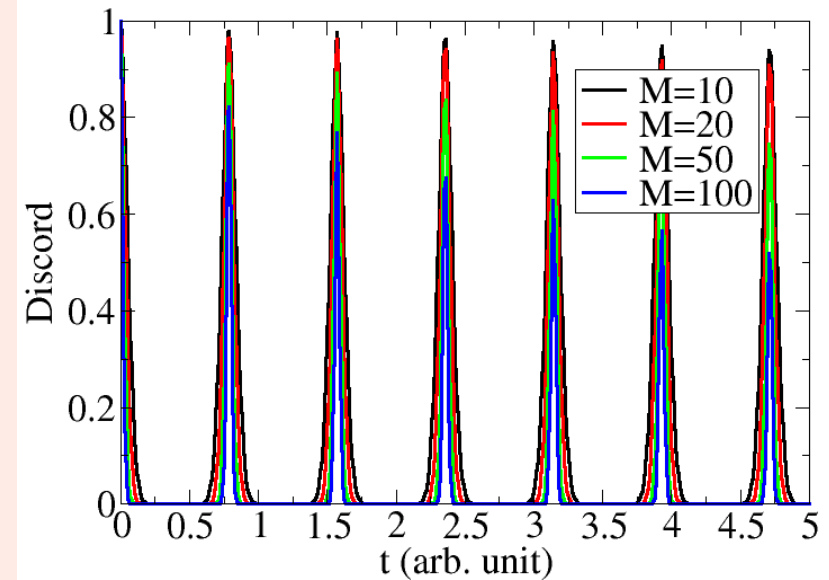
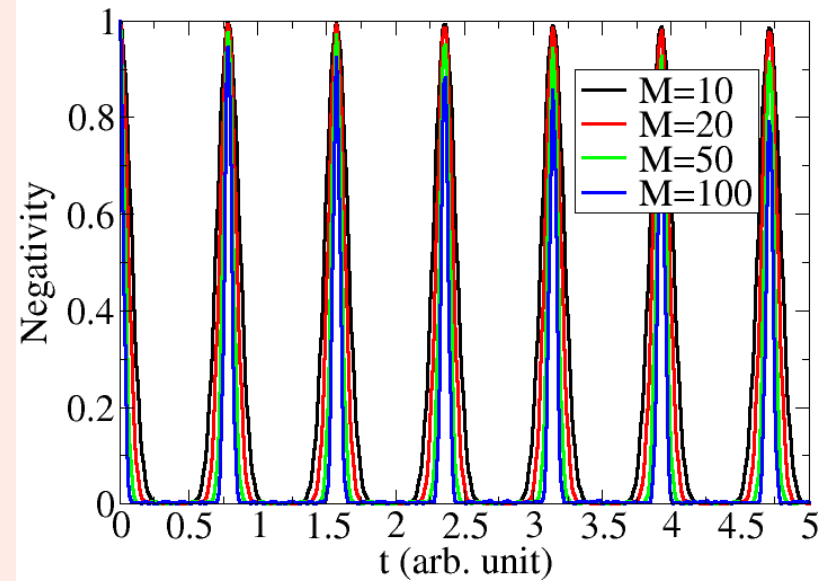

Results 3

1/f noise

Monotonic decay of correlations

The decay increases with the number of fluctuators

Independent environments preserve better the correlations than a common bath

1/f² noise

Damped oscillating decay of correlations

The decay increases with the number of fluctuators

In contrast to the case of pink noise, quantum correlations are less degraded by a common environment with respect to two independent baths.

- Quantum discord and entanglement show the same qualitative behavior
- Suitable environment engineering allows preservation of coherence in systems affected by colored noises.

Conclusions

- ✓ Quantum correlations are important because they are a **resource** for quantum information processing and communication
- ✓ The unavoidable interaction with an external environment **destroys** the quantum correlations
- ✓ We analyzed a simple model of a two qubit system under the effect of **noises** typical of the solid state devices.
- ✓ Different effects depending on the **nature** of the environment
- ✓ Different **robustness** of correlations for independent and common baths.

Conclusions

- ✓ Quantum correlations are important because they are a **resource** for quantum information processing and communication
- ✓ The unavoidable interaction with an external environment **destroys** the quantum correlations
- ✓ We analyzed a simple model of a two qubit system under the effect of **noises** typical of the solid state devices.
- ✓ Different effects depending on the **nature** of the environment
- ✓ Different **robustness** of correlations for independent and common baths.

Future perspectives...

- ◆ Analyzing the effect of $1/f^\alpha$ noises
- ◆ Evaluating the non-Markovianity of the environment
- ◆ Extending the model to systems of two qudits (N degrees of freedom)